

Dimensions in cm. Standard load per parking place max. 2000 kg (max. wheel load 500 kg).
(Comfort Type load per parking place max. 2300 kg (max. wheel load 575 kg).)

Layout Dimensions

Single Platform P 503 EP for 1 car

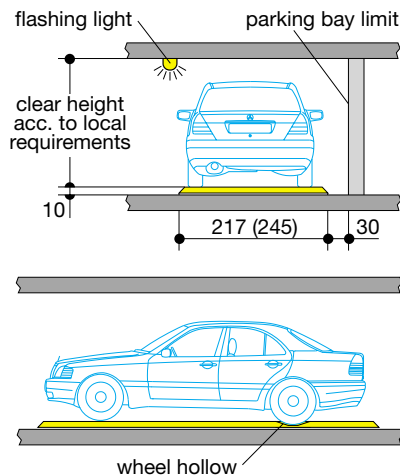
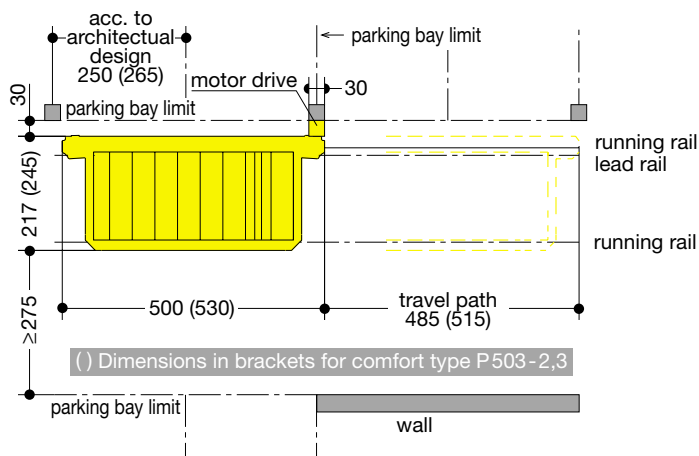

Tandem Platform P 503 TP for 2 cars behind each other

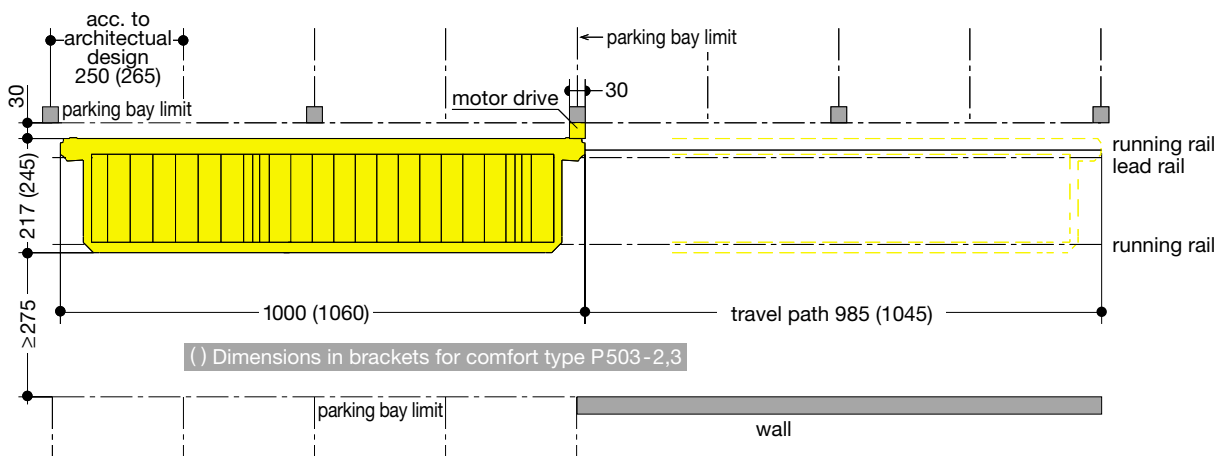

	Standard 503 EP - 2,0	Comfort 503 EP - 2,3	Standard 503 TP - 2,0	Comfort 503 TP - 2,3
quantity of cars	1	1	2	2
car length [m]	5,00	5,30	5,00	5,30
car weight [kg]	2.000	2.300	2.000	2.300
platform length [m]	5,00	5,30	10,00	10,60
travel path [m]	4,85	5,15	9,85	10,45
platform width [m]	2,17	2,45	2,17	2,45

Notes

1. Cars with higher wheel load or weight cannot park or drive over empty platforms – first move, then drive.
2. The manufacturer reserves the right to modify or alter above specifications.
3. We do not recommend installing longitudinal platforms in two way drive areas or in front of mechanical car parking systems, walkways, doors or emergency exits.
4. The parking platforms, max. height approx. 10 cm, have ramped edges and corners and it is therefore possible to drive over them by car.
5. In the case that local requirements require minimum ceiling heights, please remember to add the platform height.

Evenness and tolerances

According to safety regulations and VdTÜV/CEOC recommendations the danger of trapping between nonparallel platforms edges and the ground has to be prevented. The distance between the lower flange of the platforms and the garage ground must therefore not exceed 2 cm.

To adhere to the safety regulations and VdTÜV/CEOC recommendations and to get the necessary even ground, the tolerances of evenness to DIN 18202, table 3, line 3, must not be exceeded. Therefore exact levelling of the ground by the client is essential.

Abstract from DIN 18202, table 3

column	1	2	3	4	5	6
line	reference	Vertical measurements as limits in mm with measuring points distances in m to*				
		0,1	1	4	10	15
2	Unfinished to surface of covers, subconcrete and subsoils for higher demands, e.g. as foundation for cast plaster floor, industrial soils, paving tiles and slabstone paving, compound floor paving. Finished surfaces for minor purposes, e.g. warehouses, cellar.	5	8	12	15	20
3	Finished grounds, e.g. floor pavement serving as foundation for coverings. Coverings, tile coverings, PVC flooring and glued coverings.	2	4	10	12	15

* Intermediate values are to be taken out the diagram and must be rounded-off to mm.

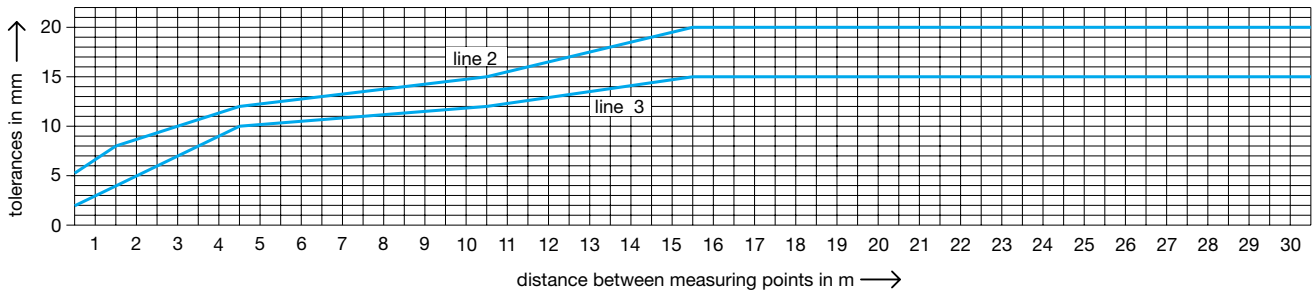

Measuring points

The evenness of a surface is checked independently of its position and slope by bore hole gauges between two check points on the surface. WÖHR normally make a random test using single measurements in case of obviously inaccurate surfaces.

For uniform examination of the evenness of the ground surface the following points are defined as measuring and check points:
 a) for surface recess
 b) for finished floor

a) Layout for surface recess width 270 (300) cm.

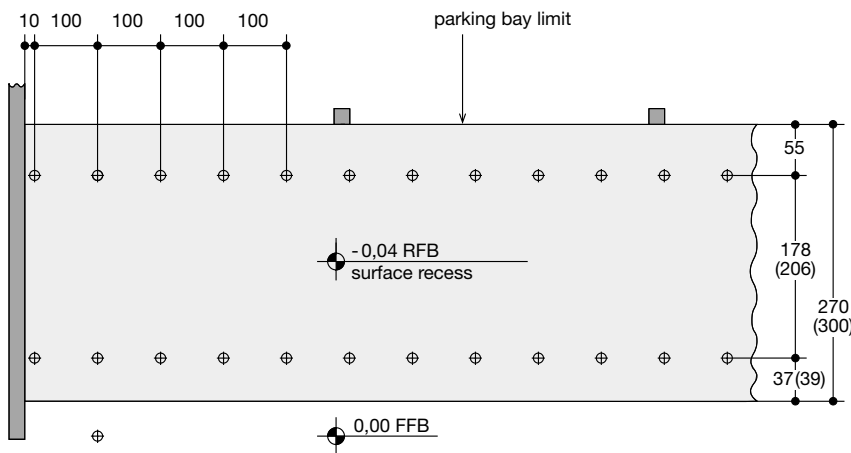

⊕ Measuring points at 100 cm points for checking unevenness acc. to DIN 18202, table 3, line 2, or acc. diagram

() dimensions in brackets for comfort type P503-2,3

b) Layout for finished floor after placing floor pavement

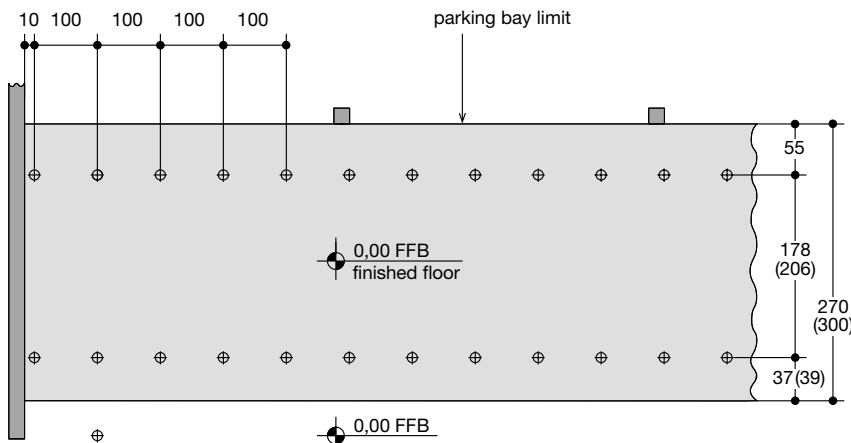

⊕ Measuring points at 100 cm points for checking unevenness acc. to DIN 18202, table 3, line 3, or acc. diagram

() dimensions in brackets for comfort type P503-2,3

Track and floor details

The moving rail load of each platform wheel is max. 400 kg. (EP 2,0 to = 4/3, TP 2,0 to = 7/7, EP 2,3 to = 5/4, TP 2,3 to = 9/9 each longitudinal base). Concerning the evenness of the ground floor, we refer to page 2 »Evenness and tolerances«.

The two running rails are used for levelling the finished floor – for tolerances see page 2.

The running rails are mounted on top of the highest point found in the area of installation – see page 2 »Measuring points«.

The running rails are fixed and installed in accordance with the specified tolerances. Unevenness beyond those requirements leads to higher installation as well as finishing floor costs.

The finish floor is leveled to the top of the running rails – see page 2 »Evenness and tolerances«. The leading rail is mounted only after the finish floor is hardened.

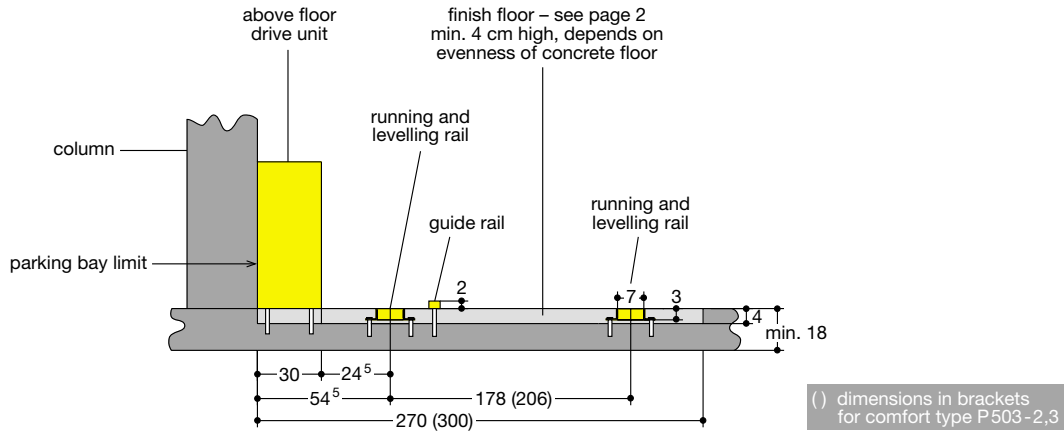

Drainage

Due to safety reasons the distance between finished floor and platform may not exceed 2 cm to avoid any danger to persons feet.

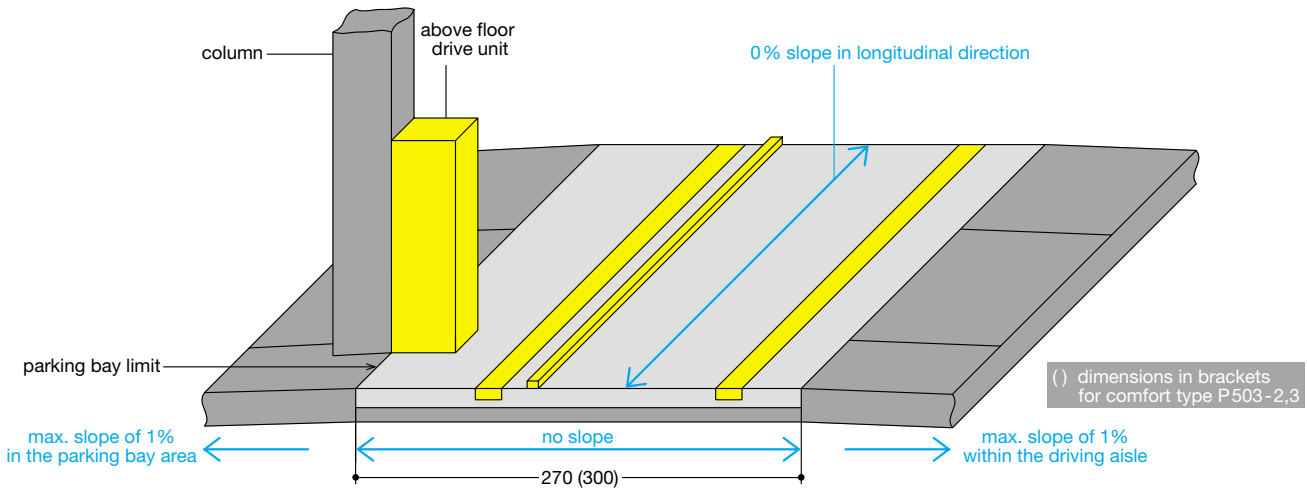

Above floor drive unit

This drive solution is used for new garage buildings and for existing car parks. It is mounted in front of columns using the available space and avoiding pit arrangements. The above floor drive unit has a moveable cover with electrical sensors. If the cover is moved the platform stops immediately in order to avoid any accidents. In the case of garage renovations consider a finish floor to attain the evenness tolerances.

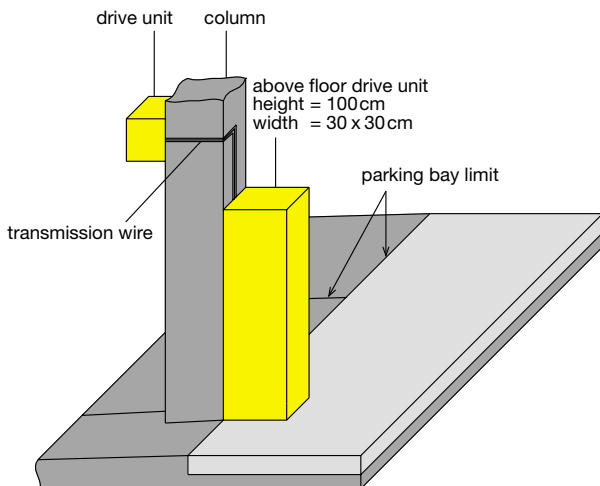

Drive unit under floor

This version is fitted in new buildings or when the installation of the parking platform drives does not depend on columns. In order to make sure that no water can penetrate through the Helfamin PG 29 pipe into the motor, the empty pipe with the transmission wire must be fitted and embedded in the columns and walls at least up to 150 cm above the ground.

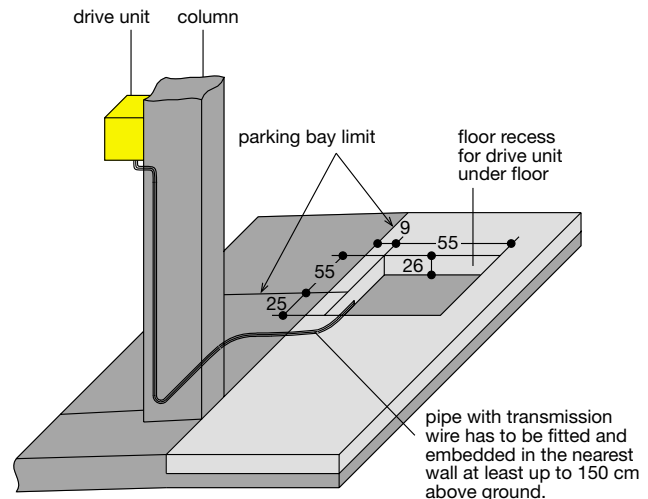

Function

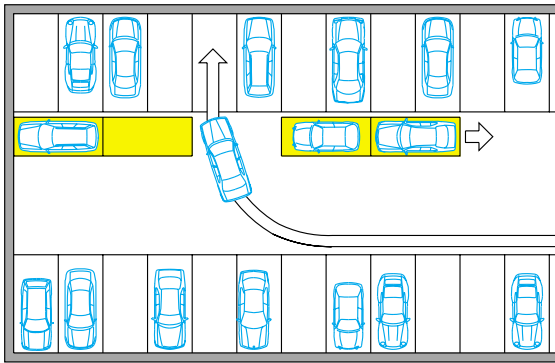

Occupied parking platforms are shifted by means of hold to run device until parking places behind or in front of/opposit of them can be crossed.

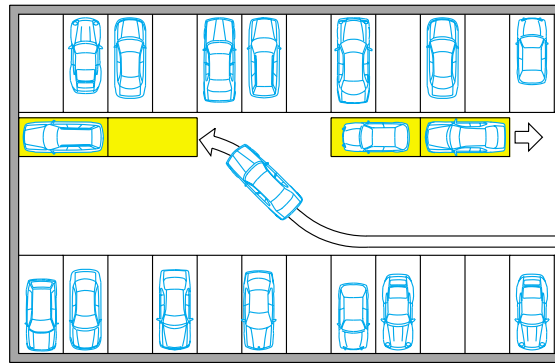

Parking places on platforms are directly driven onto or the parking platforms are shifted so that enough driving space is available to drive onto and park.

Help for planning

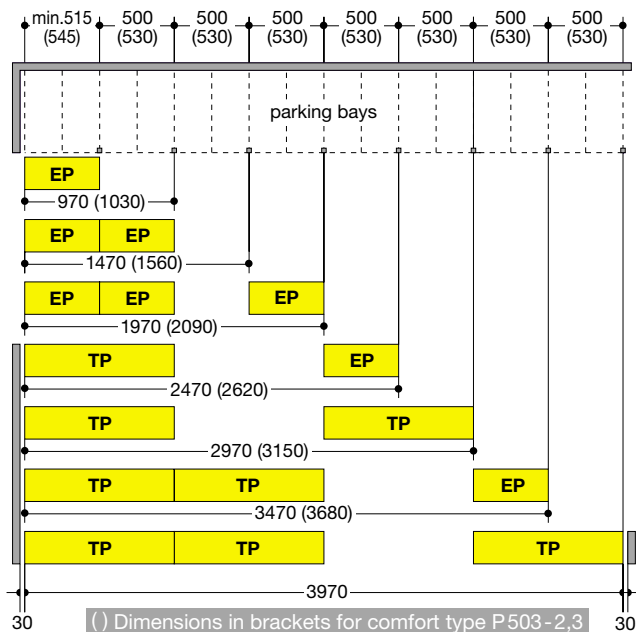

1. If parking places are opposite each other, the axials must coincide. If it is not possible, platform extensions must be provided.
2. Parking platforms with incorporated drives (current supply with cable), which have a longer shifting way than the platform length are available for special cases when standard drive units are not possible.
3. For Single Platforms (EP) we recommend a minimum distance of 650 cm to the wall at the end of the driving lane, starting from the turning point of the platform drive. Otherwise the conventional parking places behind cannot be used comfortably.
4. The length of a unit group of parking platforms must not exceed 40 m. Several units can be added in very long driving lanes.

Illumination

Illumination has to be considered acc. to local requirements by client.

Dimensions

All dimensions are in cm.

Maintenance

Regular maintenance by qualified personnel can be provided by means of an Annual Service Contract. If this option is not selected we do advise that the following are undertaken on a regular basis to protect against corrosion:

- re-coat damaged areas of paintwork.
 - clean the galvanised parts and metal sheets to prevent the building-up of dirt, oil deposits, winter salts, etc.
- In addition the garage should be aired regularly.

Product liability

Wöhr does not take any liability for damages due to squeezing danger because the evenness tolerances are not fulfilled. The distance between the lower edge of the platform and the finished floor may not exceed 2 cm.

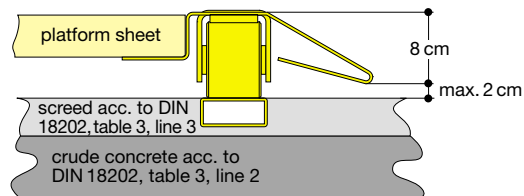

Noise

Ball bearings of the rollers provide a low sound level.

Protection against corrosion

Metal sheets and frames of parking platforms are made of hot-dip galvanized sheet according to the german regulation DIN 17162, NA 275 g/m². Guide rails are hot-dip galvanized according to the german regulation DIN 50976, approx. 55 µm zinc coating. Steel parts are sandblasted and primed, similar to the color RAL 7032.

Conformity test

All our systems are checked according to EC machinery directive 98/37/EG and the VdTÜV-recommendation Conveyor technology 1505.

Control

The control of the parking platforms is carried out by hold-to-run device with a left/right buttons. The current supply must be provided by the client with 5 x 2,5 mm², 230/400 V, 50 Hz to the switch box of the installation. Electrical power schedules are available on request.

Electrical installation

